

Other threads available:
NPT 1" 1/4
G 3/4 (BSPP)

AC1PLA
density > 1,0kg/dm3

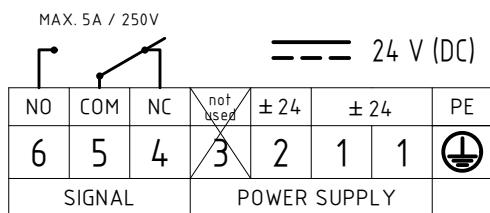
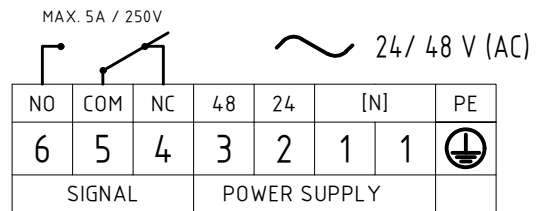
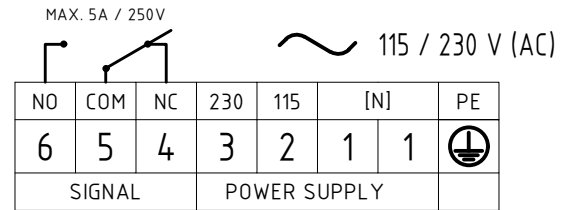

Terminals : male FASTON (.250 series / 6,3x0,8 mm)

PFG57

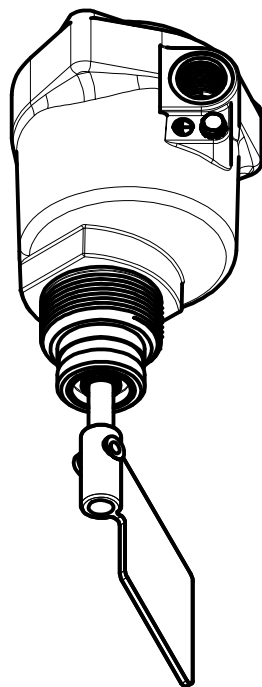

Model	PFG57
Weight	0,9 [kg]
Power supply	- Bivoltage 115/230[V] (50...60Hz) - 4[W] - Bivoltage 24/48[V] (50...60Hz) - 4[W] - DC 24[V] ±15% - 4[W]
Signal	SPDT / max. 5[A]-250VAC
IP grade	IP65
Housing	Aluminium (powder coated)
Connection	G 1" 1/2 - Aluminium
Ambient temperature	-20 < Ta < +70 [°C] -40 < Ta < +70 [°C] <i>LOW TEMPERATURE versions only (PFG.../B)</i>
Process temperature	-20 < Tp < +70 [°C] -40 < Tp < +70 [°C] <i>LOW TEMPERATURE versions only (PFG.../B)</i>
Pressure range	+0,8 ... +1,1 bar
Directives	2011/65/EU (RoHS) 2014/30/EU (EMC) 2014/34/EU (ATEX) 2014/35/EU (LVD)
ATEX Marking	Ex II 1/2 D Ex ta/tb IIIC T85°C IP65 Da/Db Ex II 3 D Ex tc IIIB T85°C Dc (Lamp version)
IECEX Marking	Ex ta/tb IIIC T85°C Da/Db

® CAMLogic
Via dell'Industria 12
42025 Cavriago (RE) - ITALY
www.camlogic.it

CAMLOGIC

DRAWING N. 0602_0006_00

SHEET: 1 OF 5

GENERAL TOL.: ISO 2768-mH

UNLESS OTHERWISE SPECIFIED DRAWING FROM CAD SYSTEM - REFER TO 3D MODEL FOR MISSING DIMENSION - NO MANUAL MODIFICATION ALLOWED

SCALE: 1:3

DRAWN NR DATE 21.09.2021

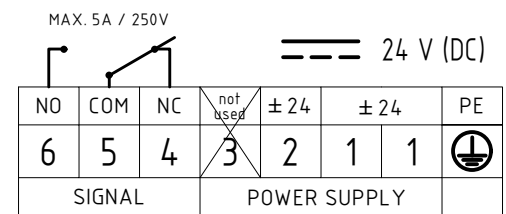
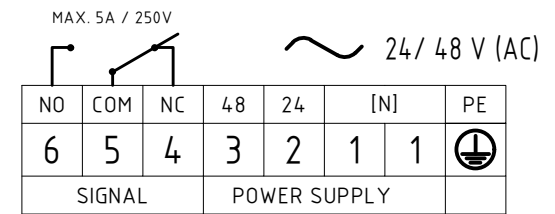
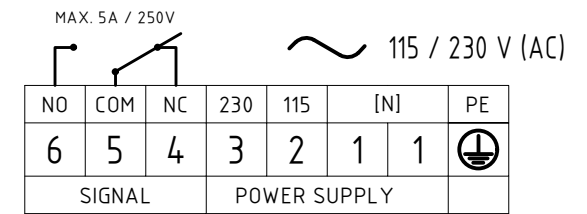
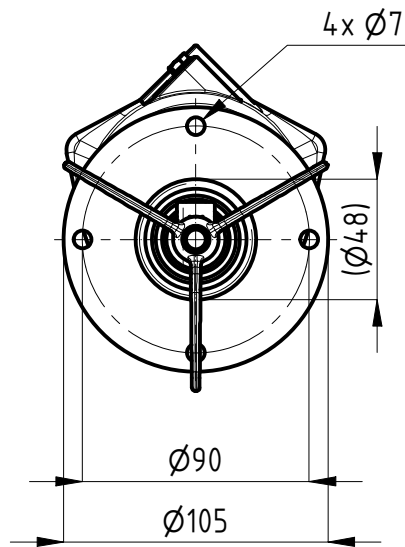
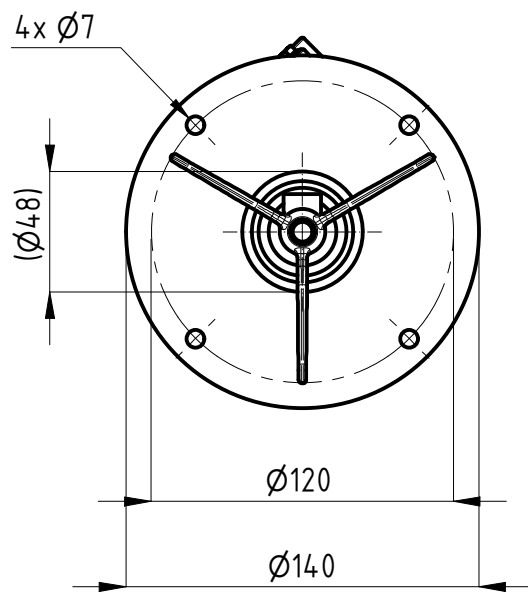

Terminals : male FASTON (.250 series / 6,3x0,8 mm)

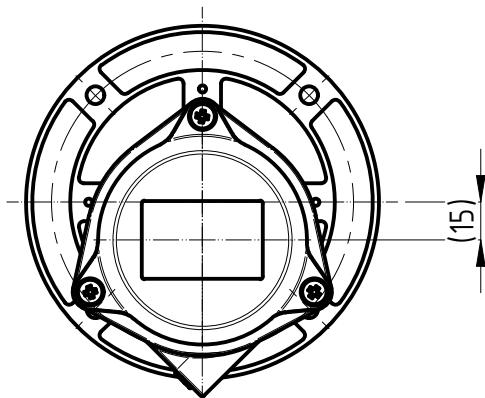
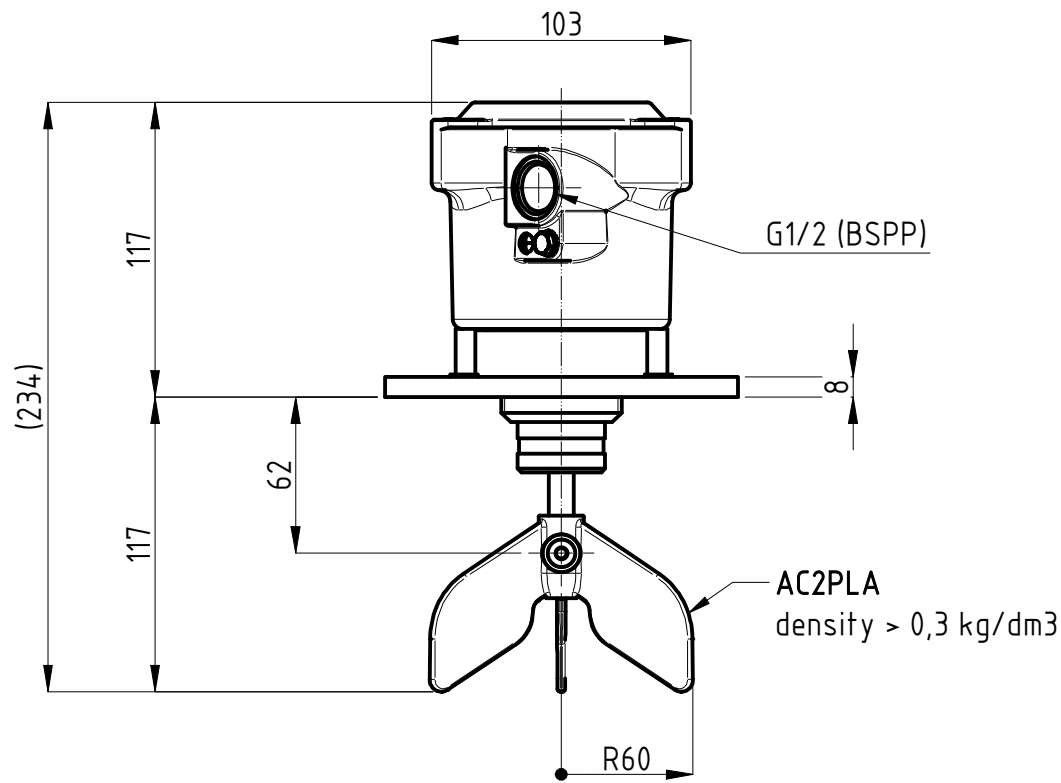

PFG57/F

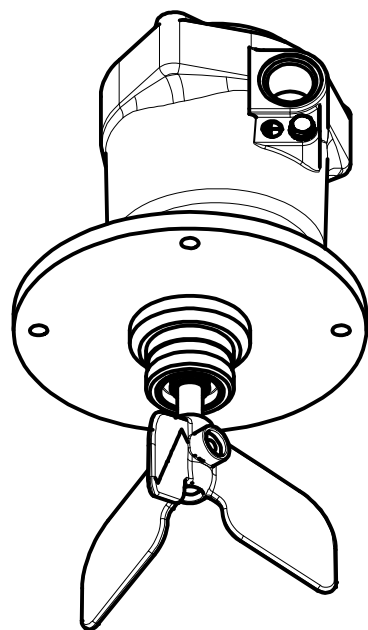

Model	PFG57/F
Weight	1,2 [kg]
Power supply	- Bivoltage 115/230[V] (50...60Hz) - 4[W] - Bivoltage 24/48[V] (50...60Hz) - 4[W] - DC 24[V] ±15% - 4[W]
Signal	SPDT / max. 5[A]-250VAC
IP grade	IP65
Housing	Aluminium (powder coated)
Connection	Flange - Aluminium
Ambient temperature	-20 < Ta < +70 [°C] -40 < Ta < +70 [°C] <i>LOW TEMPERATURE versions only (PFG.../B)</i>
Process temperature	-20 < Tp < +70 [°C] -40 < Tp < +70 [°C] <i>LOW TEMPERATURE versions only (PFG.../B)</i>
Pressure range	+0,8 ... +1,1 bar
Directives	2011/65/EU (RoHS) 2014/30/EU (EMC) 2014/34/EU (ATEX) 2014/35/EU (LVD)
ATEX Marking	Ex II 1/2 D Ex ta/tb IIIC T85°C IP65 Da/Db Ex II 3 D Ex tc IIIB T85°C Dc (Lamp version)
IECEX	Ex ta/tb IIIC T85°C Da/Db

<p>® CAMLogic Via dell'Industria 12 42025 Cavriago (RE) - ITALY www.camlogic.it</p>		DRAWING N.	SHEET:
		0602_0006_00	2 OF 5
GENERAL TOL.: ISO 2768-mH	UNLESS OTHERWISE SPECIFIED DIMENSION ARE IN [mm]	DRAWING FROM CAD SYSTEM - REFER TO 3D MODEL FOR MISSING DIMENSION - NO MANUAL MODIFICATION ALLOWED	SCALE: 1:3
			REV: 1 DATE 21.09.2021

EXTENSIONS

L1 [mm]

200

300

400

500

600

700

800

900

1100

1400

1700

1900

2400

2900

other lengths available on request, up to 3m

Extension w/o protection

PSP : galvanized steel

PSPX : stainless steel

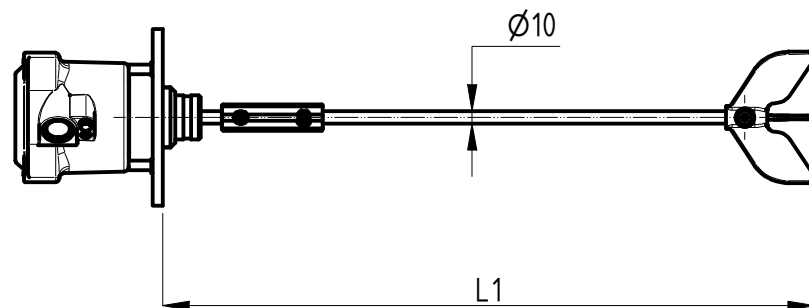

Extension with external protection

PCP : galvanized steel

PCPX : stainless steel

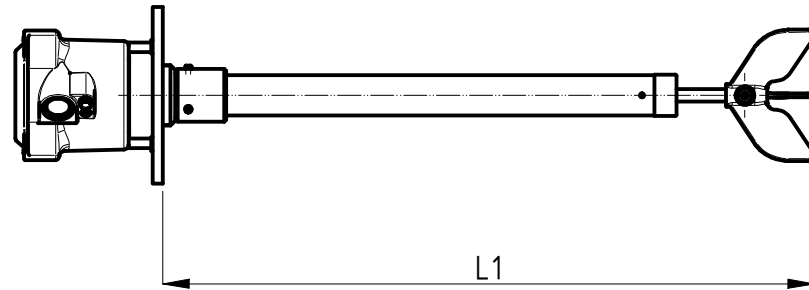

L1 [mm]

500

600

700

800

900

1100

1400

1700

1900

2400

2900

other lengths available on request, up to 3m

Adjustable extension w/o protection

PRS : galvanized steel

PRSX : stainless steel

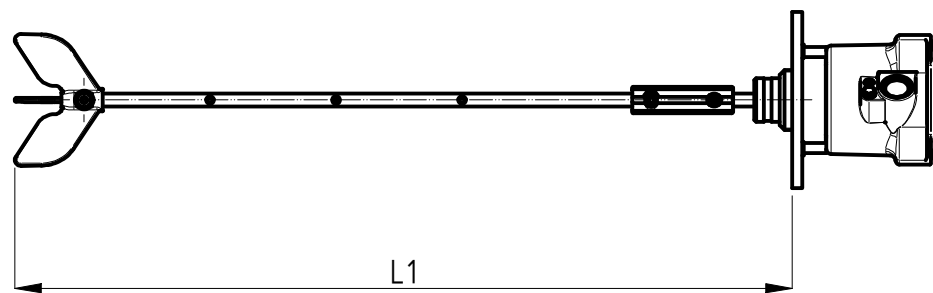

Extension with external protection

PRP : galvanized steel

PRPX : stainless steel

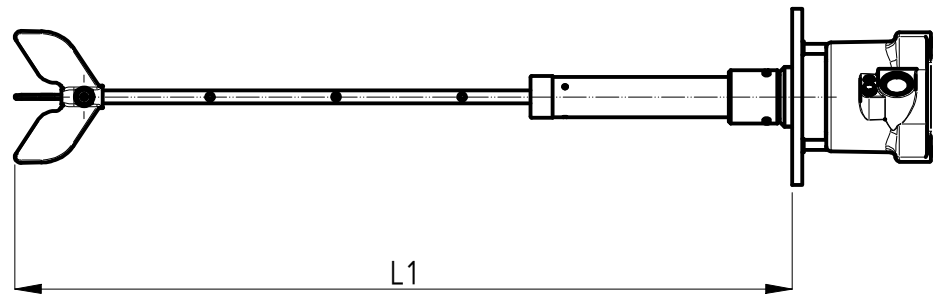

L1 [mm]

500

600

700

800

900

1000

1200

1500

2000

2500

3000

4000

L1 [mm]

5000

6000

7000

8000

9000

10000

11000

12000

other lengths available on request, up to 12m

Flexible extension

PF : galvanized steel

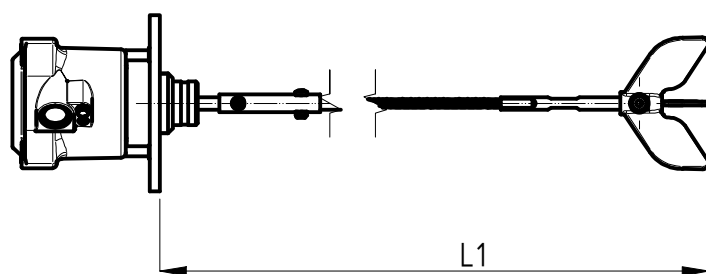

NOTE : lengths may slightly differ from the tables according to the type of connection, model type and paddle chosen

CAMLogic
Via dell'Industria 12
42025 Cavriago (RE) - ITALY
www.camlogic.it

CAMLOGIC

DRAWING N. 0602_0006_00

SHEET: 3 OF 5

REV: 1

GENERAL TOL.: ISO 2768-mH

UNLESS OTHERWISE SPECIFIED DRAWING FROM CAD SYSTEM - REFER TO 3D MODEL FOR MISSING DIMENSION - NO MANUAL MODIFICATION ALLOWED

SCALE: 1:6

DRAWN NR DATE 30.09.2021

SIZE UNI A3

PADDLES

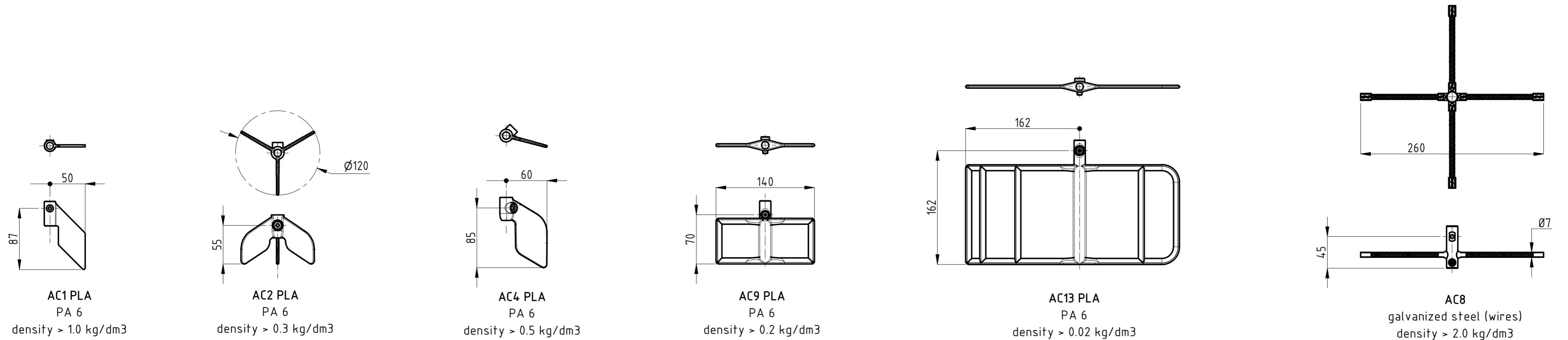
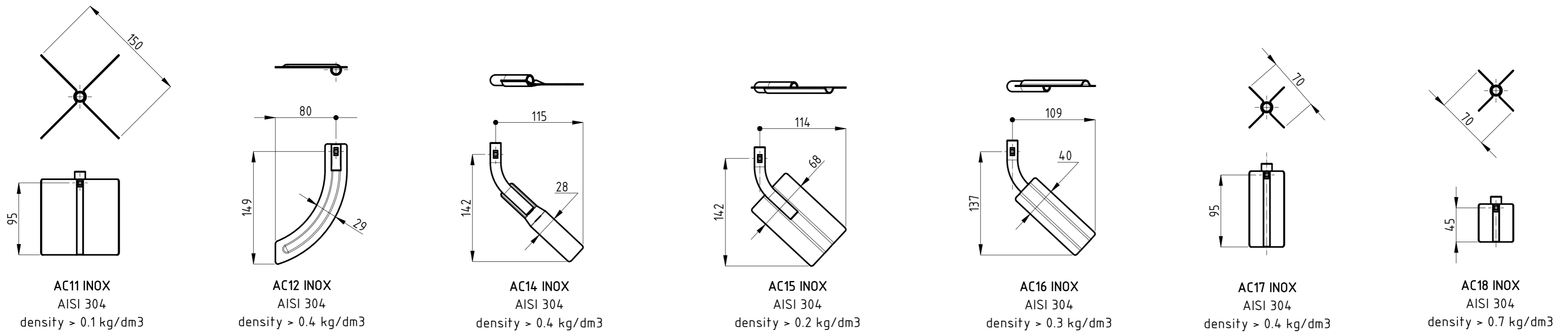
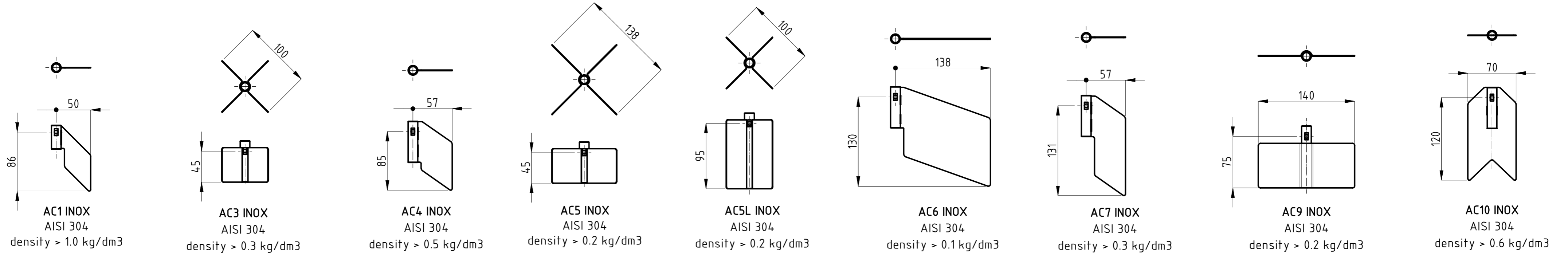

OPTIONS

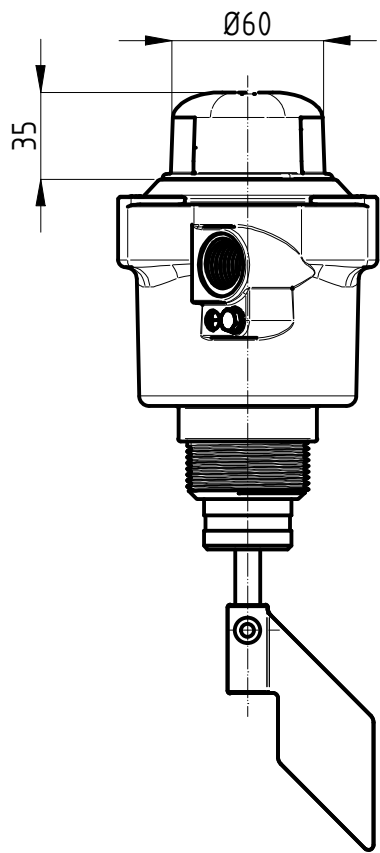

SIGNAL LAMP (PFG57.../L)

Adds a LED lamp on top. The lamp could be connected to NC contact (MIN level - empty), or NO contact (MAX level - full).

Must define a single power supply voltage: 24[V]
48[V]
115[V]
230[V]

NOTE
Model with lamp can be installed only in ATEX zone 22
Marking: Ex II 3 D Ex tc IIIB T85°C Dc

PFG57/L

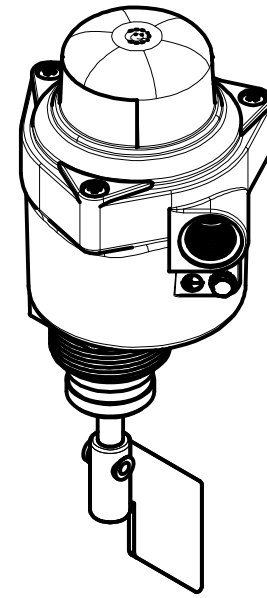

LOW TEMPERATURE (PFG57.../B)

Extends the range of use of the indicator down to a minimum temperature of -40 °C
Intelligent automatic operation: when the temperature exceeds + 20 °C it stops heating (heating OFF), it is reactivated when the temperature falls again below + 20 °C (heating ON)

Must define a single power supply voltage: 24[V]
48[V]
115[V]
230[V]

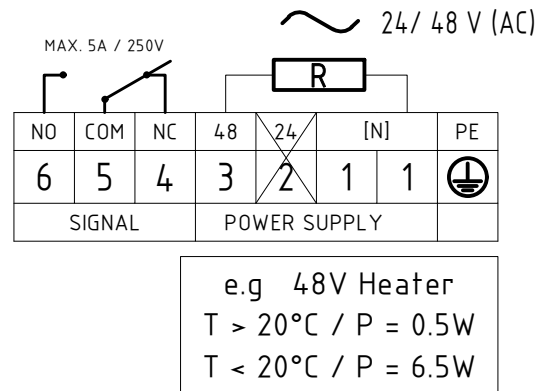

SPRING TERMINAL BLOCK

Terminals with spring terminal design.
No tool needed for wires connection.
0,13 - 2,5mm² (AWG26 - AWG14)

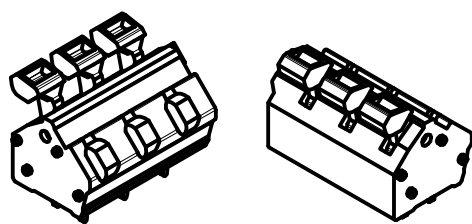

SCREW TERMINAL BLOCK

Terminals with screw terminal design (flat head)
0,05 - 2,5mm² (AWG30 - AWG12)

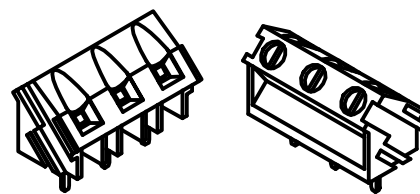

4rpm GEARMOTOR

Increase paddle speed (4 rpm) to reduce product detection delay time (response time ~ 1,5s)